

LOW-RANGE PHONE DEDICATED CHIP

- RING
 - GENERATION OF 8 MELODY TONES
(Including the 3 German Melody Tones)
 - 4 STEPS DIGITAL CONTROL ON THE AMPLIFIER OUTPUT LEVEL
- SPEECH
 - TRANSMIT GAIN EXTERNALLY ADJUSTABLE
 - RECEIVING GAIN EXTERNALLY ADJUSTABLE
 - AGC SLOPE EXTERNALLY PROGRAMMABLE
 - SOFTCLIPPING ON SENDING CHANNEL
 - RECEIVE AMPLIFIER FOR PIEZO OR ELECTRODYNAMIC TRANSDUCER
 - +6dB MODE ON RECEIVE CHANNEL
 - LINE POWER MANAGEMENT
- DIALING
 - DTMF GENERATOR
 - LOW DC MASK DURING MAKE PERIOD THROUGH MICROCONTROLLER SERIAL BUS INTERFACE
- MICROCONTROLLER INTERFACE
 - 1.79MHz CLOCK OR 3.58MHz OSCILLATOR INPUT
- MICROCONTROLLER POWER SUPPLY
- MICROCONTROLLER CONTROL INTERFACE INCLUDING SERIAL BUS
- LINE CURRENT EXTRACTOR FOR SUPPLY OF EXTERNAL PERIPHERALS

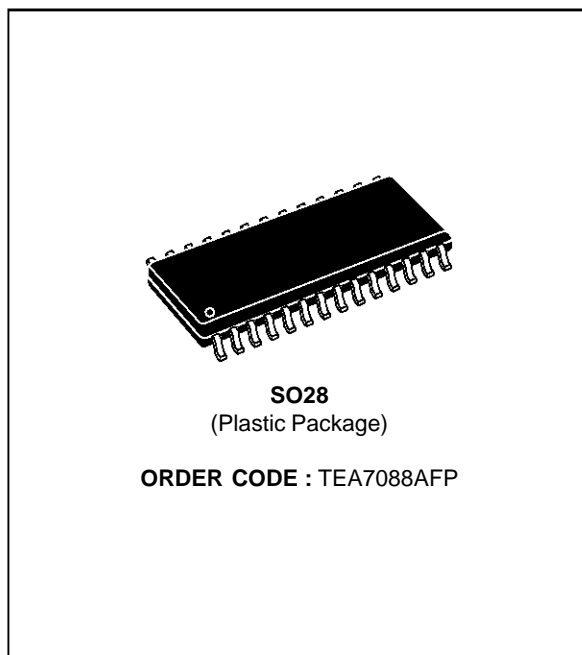

PIN CONNECTIONS

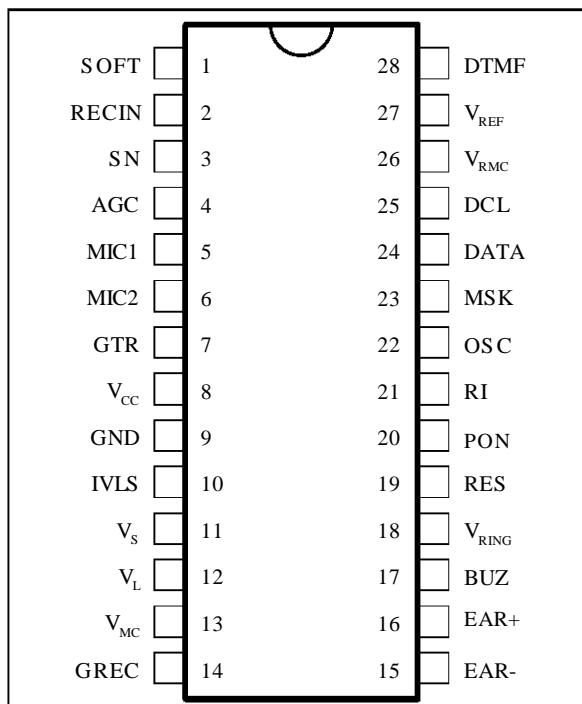

DESCRIPTION

The TEA7088A is a Telephone Analog Front End device, TAFE, which integrates the three basic functions of a standard telephone set :

- Speech network,
- DTMF generator,
- Ringer generator on buzzer.

A complete telephone set can be designed using TEA7088A associated with a low cost microcontroller.

TEA7088A

SPEECH

The speech network includes :

- a low noise transmit channel suitable for any kind of microphone transducer. Softclipping on transmit line signal is provided by the chip.
- a low noise receive channel with symmetrical outputs to be compatible with both piezoceramic and electrodynamic earpiece. An additional 6dB gain can be inserted in the receive channel through software control.
- a line length gain control (AGC) with starting point of gain regulation fixed at 25mA line current ; slope of gain regulation is externally adjustable with one resistor. AGC can be removed by hardware (maximum gain flat) or by software (-2dB flat).

The phone impedance and sidetone can be tuned through external networks.

DTMF GENERATOR

The onboard DTMF generator fulfils the CEPT requirements with an external single pole filter.

RINGER

Up to 8 different tones can be generated by the TEA7088A ringer. The digital volume control of the ringer can be performed through a specific command (4 steps). A ring indication signal is provided to the microcontroller by the TEA7088A. If more tones are requested the input RM/MSK allows to inject tones generated by the microcontroller.

FURTHER ADVANTAGES

The microcontroller power supply is provided by the TEA7088A. The power supply is specifically designed to cope with a long flash or a long ground key duration.

The TEA7088A is able to supply the necessary current to an external speakerphone circuit TEA7540 and loudspeaker amplifier TEA7532 without any additional circuitry.

Line current and reset indications are provided to the microcontroller by the TEA7088A.

The microcontroller drives the TEA7088A through a 2 wires serial interface.

PIN DESCRIPTION

Name	Pin N°	Description
SOFT	1	Transmit Softclipping Time Constant
RECIN	2	Receiving Input
SN	3	Sidetone Network Input
AGC	4	Line Current Regulation Stop Value
MIC1	5	Microphone Input
MIC2	6	Microphone Input
GTR	7	Transmit Gain Adjustment
V _{CC}	8	Transmit and Receive Part Power Supply
GND	9	Ground
IVLS	10	Line Current Source Power Supply
V _S	11	Voltage Stabilizer
V _L	12	Positive Line
V _{MC}	13	Unregulated Microcontroller Power Supply
GREC	14	Receive Gain Adjustment
EAR-	15	Negative Earphone Output
EAR+	16	Positive Earphone Output
BUZ	17	Ringer Buzzer Output
VRING	18	Ring Power Supply
RES	19	Reset
PON	20	Power On
RI	21	Ring Indicator
OSC	22	Oscillator Input
MSK	23	Mask, Ring Melody Input
DATA	24	Data Input
DCL	25	Data Clock Input
V _{RMC}	26	Microcontroller Stabilized Power Supply
V _{REF}	27	Reference Voltage (V _{CC} /2)
DTMF	28	DTMF Filter

Figure 1 : Block Diagram

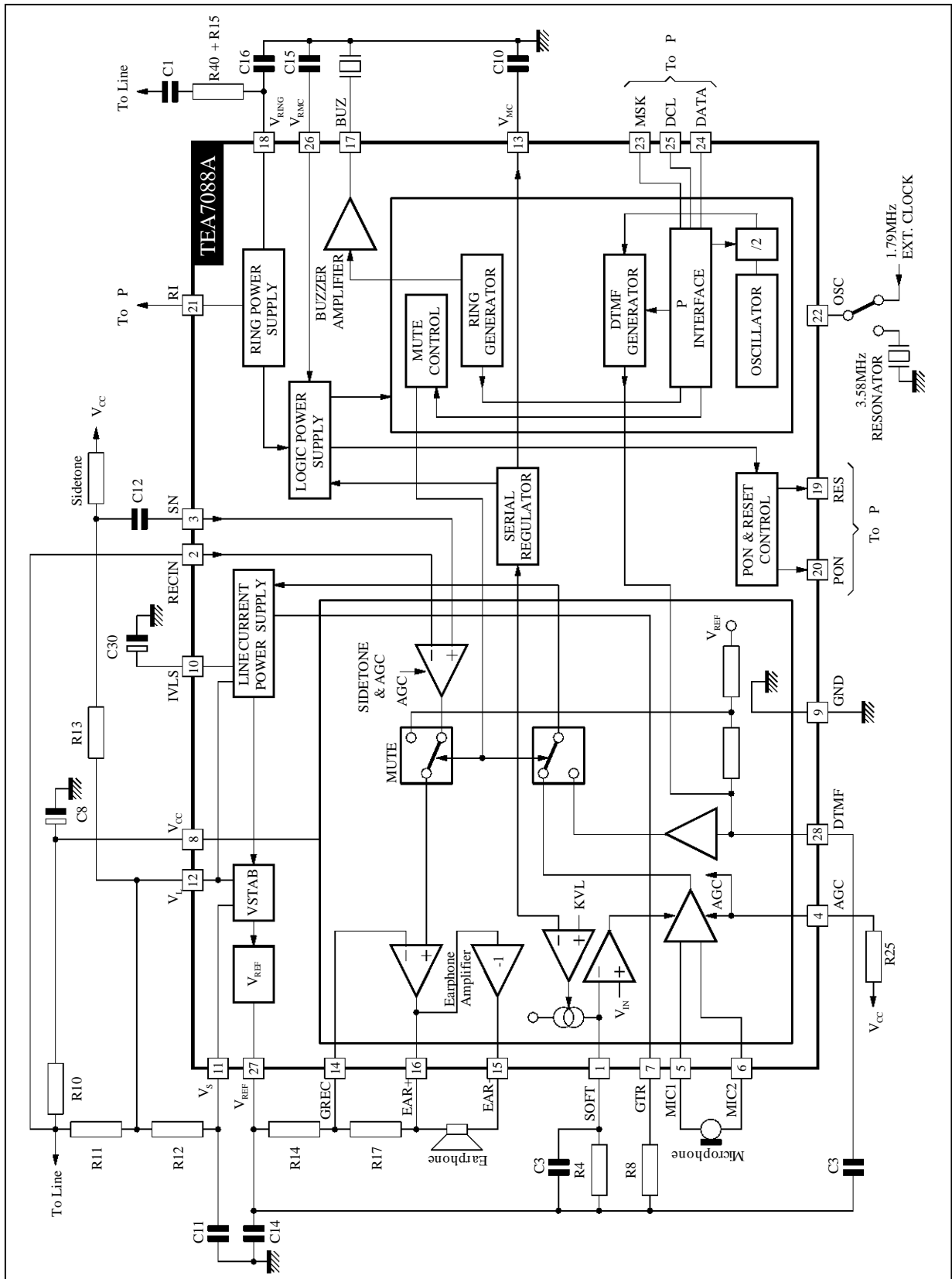

7088A-02.EPS

ELECTRICAL CHARACTERISTICS

The block diagram is given in Figure 1.

The values of the different networks used in this datasheet are defined as followed :

- The return loss is adjusted by R10 of 600Ω.
- The transmit adjust gain network R8 is calculated in order to have a gain of 46dB typical with $I_{LS} = 22\text{mA}$.
- The sidetone network ZST is set to be lower than 20dB (Vear/Vmic) on a 600Ω load on line.
- The DC characteristics are set by a resistor of 82kΩ between V_L and V_S .

Absolute Maximum Ratings

Symbol	Parameter	Value	Unit
	Authorized Voltage on		
	Pin 2 - RECIN	13	V
	Pin 3 - SN	12	V
	Pin 8 - VCC	11	V
	Pin 10 - IVLS	6	V
	Pin 12 - V_L	12	V
	Pin 13 - V_{MC}	6	V
	Pin 17 - BUZ	$V_{RING} + 0.3, \text{GND} - 0.3$	V
	Pin 18 - V_{RING}	27	V
	Pin 19 - RES	$V_{RMC} + 0.3, \text{GND} - 0.3$	V
	Pin 20 - PON	$V_{RMC} + 0.3, \text{GND} - 0.3$	V
	Pin 21 - RI	$V_{RMC} + 0.3, \text{GND} - 0.3$	V
	Pin 22 - OSC	$V_{RMC} + 0.3, \text{GND} - 0.3$	V
	Pin 23 - MSK	$V_{RMC} + 0.3, \text{GND} - 0.3$	V
	Pin 24 - DATA	$V_{RMC} + 0.3, \text{GND} - 0.3$	V
	Pin 25 - DCL	$V_{RMC} + 0.3, \text{GND} - 0.3$	V
	Pin 26 - V_{RMC}	5	V
I_{LINE}	Line Current	120	mA
I_{RING}	Ring Current	50	mA
T_{oper}	Operating Temperature	-25, +70	°C
T_{stg}	Storage Temperature	-55, +150	°C
T_j	Junction Temperature	-25, +150	°C

7088A-02.TBL

DC Characteristics ($T_{amb} = 25^\circ\text{C}$; Logic in Default Mode unless otherwise noted)

Symbol	Parameter	Test Conditions	Min.	Typ.	Max.	Unit
V_L	Line Voltage - In Speech and DTMF Mode - In Mask Mode	Test 1 $I_L = 22\text{mA}$ $I_L = 90\text{mA}$ $I_L = 22\text{mA}$	4 6.7	4.6 7.5	5.2 8.3 3	V V V
I_{VRMC}	Stabilized Supply Voltage - Output Current	Test 1, $I_L = 22\text{mA}$	1.5			mA
V_{RMC}	- Output Voltage	$I_{RMC} = 1.5\text{mA}$	3.15	3.35	3.55	V
I_{VMC}	Unstabilized Supply Voltage - Start up Current - Output Current	Test 1, $I_L = 22\text{mA}$ $V_{MC} = 2.5\text{V}, I_{VRMC} = 1.5\text{mA}$ $V_{MC} = 3.6\text{V}, I_{VRMC} = 0\text{mA}$	10	15 3		mA mA
I_{LS}	Line Current Source Supply	Test 1, $V_{LS} = 0\text{V}; V_{MC} = 3.6\text{V}$ $I_L = 22\text{mA}$ $I_L = 90\text{mA}$	10 67	14 75	18 82	mA mA

The line current source supply depends of I_L :

- For $I_L < 20\text{mA}$: $I_{LS} (\text{mA}) = 0.765 \times I_L (\text{mA}) - 1.4\text{mA}$
- For $I_L > 20\text{mA}$: $I_{LS} (\text{mA}) = 0.92 \times I_L (\text{mA}) - 4.5\text{mA}$

On this pin the maximum output level is : $V_{10} = V_{12} - (1.2 + 10 \times I_{LS})$ and $V_{10} < 6\text{V}$

ELECTRICAL SPECIFICATIONS (continued)**AC Characteristics** ($T_{amb} = 25^{\circ}\text{C}$; $R_L = 600\Omega$; Logic in Default Mode unless otherwise noted)

Symbol	Parameter	Test Conditions	Min.	Typ.	Max.	Unit
R1	Return Loss	Test 2, $I_L = 22\text{mA}$ $f = 300/3400\text{Hz}$, $V_{AC} = -10\text{dBV}$	17			dB

Transmit Characteristics($T_{amb} = 25^{\circ}\text{C}$; $R_L = 600\Omega$; $f = 1\text{kHz}$; Logic in Default Mode unless otherwise noted)

Symbol	Parameter	Test Conditions	Min.	Typ.	Max.	Unit
Gtx	Microphone Gain	Test 3, $V_m = -55\text{dBV}$ $R8 = 1.3\text{k}\Omega$, $R25 = 3.9\text{k}\Omega$ $I_L = 22\text{mA}$ $I_L = 90\text{mA}$				
Gtxl			45	46	47	dB
Gtxs			38	40	42	dB
Zmic	Microphone Input Impedance	between MIC1 & MIC2	32	40	48	k Ω
Ntx	Noise	Test 3, $2\text{k}\Omega$ on microphone inputs, $I_L = 22\text{mA}$		-76		dBmp
Mmic	Microphone Mute	Test 3, $V_m = -55\text{dBV}$, $I_L = 22\text{mA}$	60			dB
Dtx V _L Max.	Soft Clipping - Distortion - Maximum Level on Line	Test 3, $I_L = 22\text{mA}$, see Figure 2 $V_m = -41\text{dBV}$ $V_m = -34\text{dBV}$		1.5	2	% V _p

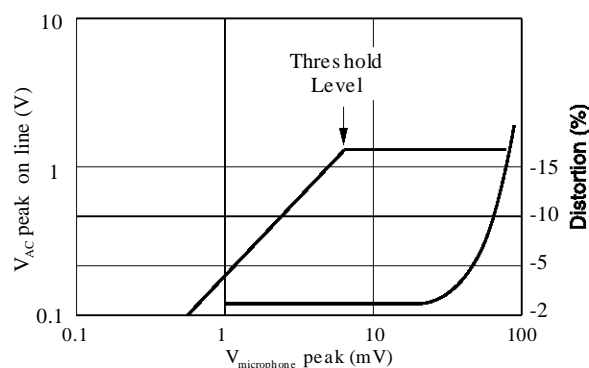
Figure 2 : Softclipping

7088A-03.EPS

The maximum gain Gtl is adjustable between 44 and 56dB with R8 :

$$G_{txl} = 20 \log \left(820 \cdot \frac{R10 // R_L + R11}{R8 // 50\text{k}\Omega} \right)$$

The AGC variation is programmed with one resistor connected on Pin AGC. I_{SL} is the line current at which the gain must be decreased by 6dB.

$$R25 (\Omega) = \frac{300}{I_{SL} - 5\text{mA}} \quad (R25 > 2.6\text{k}\Omega)$$

For line current lower than I_{LL} or higher than I_{SL} , The transmit and receive gains have a constant value.

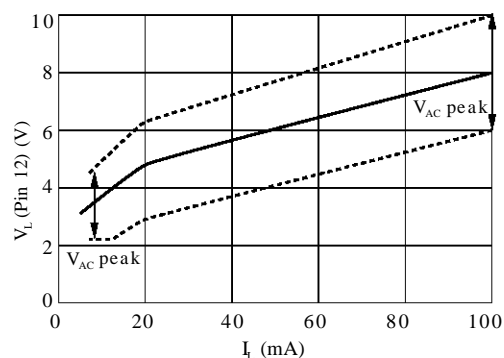
Figure 3

7088A-04.EPS

If no resistor or a resistor higher than $300\text{k}\Omega$ is connected on Pin AGC, the gain is constant and equal to Gtxl and Grxl. $\pm 0.5\text{dB}$.

AGC can be inhibited also through MCU code "010100". In this case Tx and Rx gains are fixed 2dB lower than the maximum gain.

The minimum saturation voltage of the TEA7088A respect to ground is 2.2V. On long line, when the voltage over TEA7088A is low, the softclipping function automatically limits the AC dynamic to avoid to reach the 2.2V limit on TEA7088A respect to ground.

ELECTRICAL SPECIFICATIONS (continued)

Receive Characteristics ($T_{amb} = 25^{\circ}C$; $R_L = 660\Omega$; $f = 1kHz$)

Symbol	Parameter	Test Conditions	Min.	Typ.	Max.	Unit
E_{ff}	Sidetone $E_{ff} = (V_{ear^+} - V_{ear^-}) / V_m$	Test 3, $V_m = -55dBV$, $I_L = 22mA$, $R_{14} = 10k\Omega$, $R_{17} = 15k\Omega$			22.5	dB
G_{RXI} G_{RXS}	Gain in Symmetric Mode $G_{rx} = (V_{ear^+} - V_{ear^-}) / V_L$	Test 6, $V_L = -14.5dBV$, $R_{14} = 10k\Omega$, $R_{17} = 15k\Omega$, $R_{25} = 3.9k\Omega$ $I_L = 22mA$ $I_L = 90mA$	0.7 -6	1.7 -4	2.7 -2	dB dB
D_r	Distortion	Test 4, $R_{ear} = 300\Omega$, $I_L = 22mA$ $V_{ear} = -12dBV$ $V_{ear} = -8dBV$			2 5	% %
N_r	Noise	Test 4, $I_L = 22mA$		-76		dBmp
V_{ear} (010010)	Earphone Mute	$I_L = 22mA$, $V_L = -14.5dBV$	60			dB
Z_{out}	Output Impedance				20	Ω

Automatic Gain Control Inhibition ($T_{amb} = 25^{\circ}C$; $R_L = 660\Omega$; $f = 1kHz$ no AGC mode selected)

Symbol	Parameter	Test Conditions	Min.	Typ.	Max.	Unit
G_{tp} G_{rp}	Transmit Gain Receive Gain	Test 3 & Test 4, $I_L = 22$ to $90mA$ Code : 010100 $V_m = -55dBV$ $V_L = -14.5dBV$	$G_{txl} -3$ $G_{rxl} -3$	$G_{txl} -2$ $G_{rxl} -2$	$G_{txl} -1$ $G_{rxl} -1$	dB dB

Ring Characteristics ($T_{amb} = 25^{\circ}C$)

Symbol	Parameter	Test Conditions	Min.	Typ.	Max.	Unit
$V_{Thri ON}$ $V_{Thri OFF}$	Ringing Threshold Voltage	Test 5 a/b RI high (see Figure 4) RI low (see Figure 4)	15 5		20 9	V V
I_{CRing}	Internal Consumption in Ring Mode	$V_{RING} = 10V$		1	1.2	mA
V_{RMC}	Microprocessor Supply Voltage		3.45	3.75	4.05	V
t_{RON}	Rise Time	$I_{RING} = 10mA$			100	ms
V_{RING}	Internal Zener Voltage		27			V
V_{bout}	Buzzer V_{out} Freq = 1312Hz Freq. Code 001111	$V_{RING} = 27V_{zener}$ (see Figure 5) Level Code (011111) Level Code (011110) Level Code (011101) Level Code (011100)	12 4.4 2.2 1	13 5.6 2.8 1.4	13.5 6.7 3.4 1.8	V_{RMS} V_{RMS} V_{RMS} V_{RMS}

Figure 4 : Ringer Hysteresis Ringer

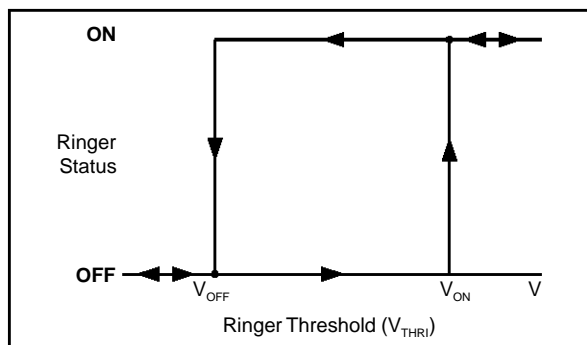
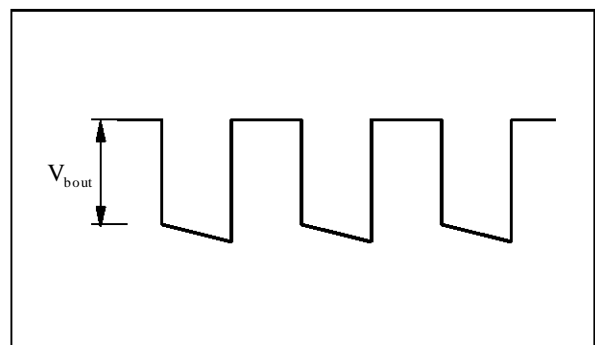

Figure 5 : Ringer Output Waveform



ELECTRICAL SPECIFICATIONS (continued)

DTMF Generator ($T_{amb} = 25^{\circ}\text{C}$; $R_L = 660\Omega$)

Symbol	Parameter	Test Conditions	Min.	Typ.	Max.	Unit
Amf	Tone Frequency Accuracy	Test 6 Pin Osc fclock = 1.79MHz oscillator off or Resonator : 3.58MHz oscillator on C13 =100nF, $I_L = 22\text{mA}$	- 0.4		0.4	%
Llf Lhf	Low Freq. Group Line Level High Freq. Group Line Level		-10 -8	-8.5 -6.5	-7 -5	dBm dBm
Pmf	Preemphasis HF/LF		+1	+2	+3	dB
t _{DON} t _{DOFF}	Rise Time Decay Time				5 5	ms ms
Cmf	DTMF Confidence Tone : Earphone level (low freq.) Earphone level (high freq.)		13 17	17 22	21 27	mV mV
-	- Unwanted Harmonics Level	(see Figure 6)	-	-	-	-

Figure 6 : Unwanted Harmonics Level in DTMF

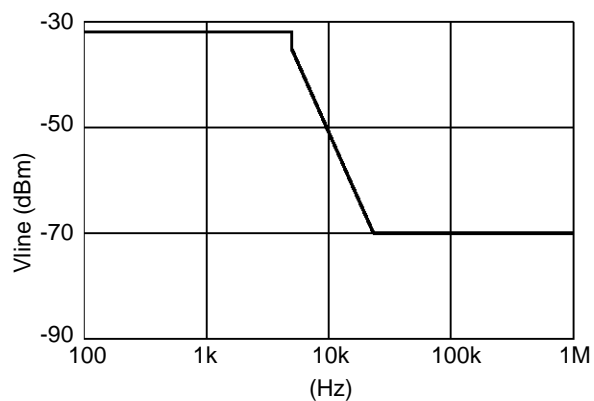
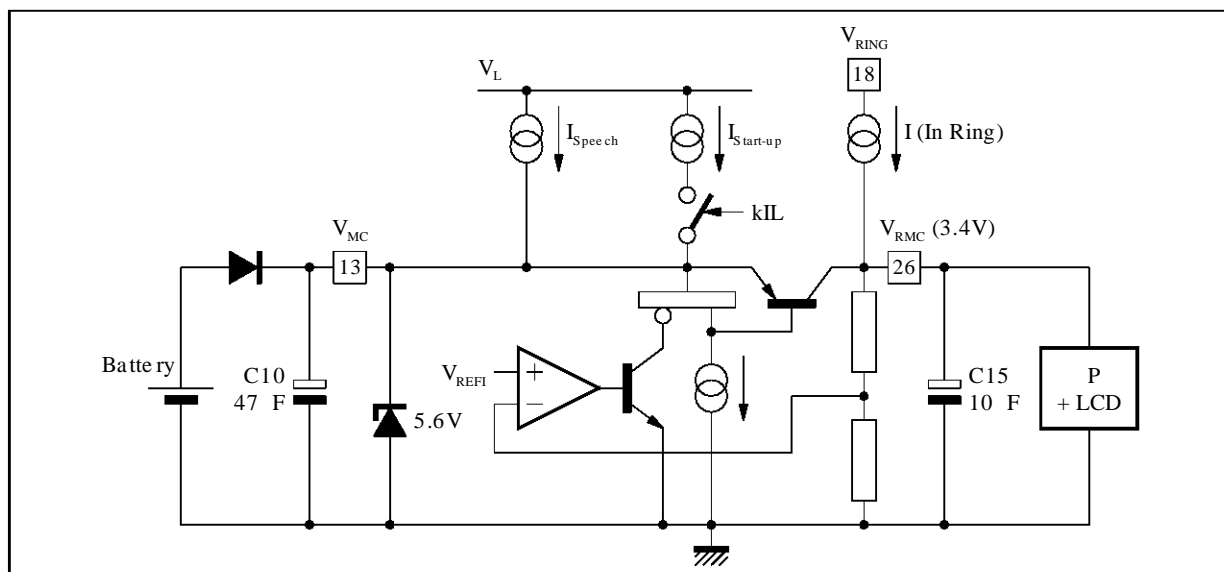

Figure 7 : Microcontroller Interface



MICROCONTROLLER INTERFACE WITH TEA7088A

All inputs can be driven by a Low level max. of $0.1 \times V_{RMC}$ and a high level min. of $0.9 \times V_{RMC}$.

Inputs MSK, DCL and DATA have internal pull-up resistors of $120k\Omega$ and input OSC has a internal pull up of $240k\Omega$.

All outputs can drive a $\pm 1mA$ typical.

Power Supply

The microcontroller is power supplied by a 3.4V regulated supply (V_{RMC}) and by an unregulated power supply (V_{MC}).

The two supplies are connected through a serial regulator. The unregulated power supply (V_{MC}) has a DC voltage equal to: $V_{12} - 0.6V$ and must be lower than 6V. It is also possible to connect a battery at Pin V_{MC} and use the regulated output at Pin V_{RMC} to supply a LCD driver.

The current consumption on the serial regulator has a typical value of $60\mu A$.

Power ON (PON)

The TEA7088A generates a power on signal (PON) as soon as the voltage on Pin V_{RMC} is higher than 2.6V ($0.75 \times V_{RMC}$ final) and the line current is present.

Note : During the break period in the loop disconnect and Flash mode and during the exchange line break, the power ON signal goes to low level. Maximum delay for Pon decay edge after I_{Line} goes to zero is 50ms (with $C8 = 47\mu F$, $C11 = 1\mu F$, $C27 = 10\mu F$).

Reset

The TEA7088A generates a rise edge Reset signal as soon as the logic power supply is higher than 2.6V ($0.75 \times V_{RMC}$ final).

RESET remains high until V_{RMC} decreases below 2.5V or the RESET control code is received. In Ring, RESET is identical to RI output.

Only new positive edge PON, derived on opening and closing the line, is forcing the default mode again. The Reset control code is only active in speech mode.

Serial Bus Interface (Data and Clock)

The serial bus uses 6 bits. A standard 8 bit bus can be used, bits a6 and a7 are not take in account by the TEA7088A. Different types of codes are used :

a) The Ring Control Code :

- Ring start up
- Output level codes

b) The Operating Code :

- Speech
- Dialing
- Microphone mute
- Earphone/Microphone mute

c) The Data Codes (DTMF, ring frequencies) :

Those data codes are stored inside the TEA7088A and are used as soon as the dialing code or the ring start code is received.

d) The Configuration Code :

- AGC / no AGC (toggle)
- No mask / mask (Low DC in "make") (toggle)
- Normal gain / normal gain +6dB, on receive channel (toggle)
- 1.79MHz external clock / 3.58MHz internal oscillator (toggle)

Those configuration codes are "Flip-Flop" codes.

For instance : The first time that the +6dB code is sent, the receive gain increases of +6dB.

If the same code is sent again, the receive gain goes back to normal value. In the same way the 3.58MHz internal oscillator can be switched OFF with a second transmission of the proper code.

e) The RESET Code :

Reset code from the MCU will reset internal logic of TEA7088A to default mode and will induce TEA7088A to generate a "RESET" status "low" to the MCU on Pin 19.

Warning : the "RESET" code deactivates the serial bus interface which is reactivated only after a "ON-HOOK/OFF-HOOK" sequence.

f) The INITIALIZATION Code :

Initialization code from the MCU will reset the internal logic of TEA7088A to default mode, but the TEA7088A will not generate reset command to the MCU on Pin 19.

MICROCONTROLLER INTERFACE WITH TEA7088A (continued)

Figure 8 : Reset and Power ON

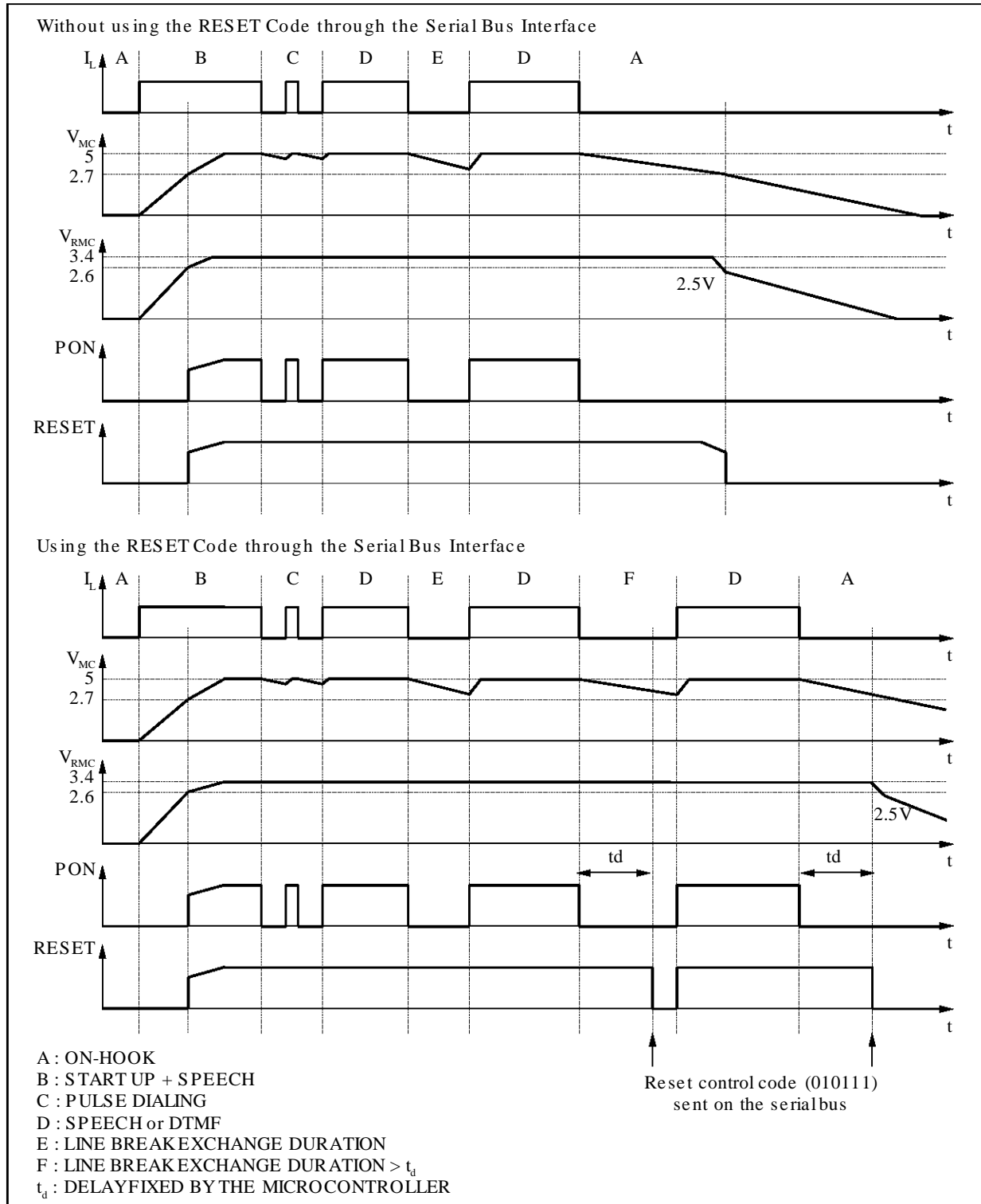

MICROCONTROLLER INTERFACE WITH TEA7088A (continued)

The Start Up Conditions of the TEA7088A

As soon as RESET is high and before sending any code the circuit is in the following default configuration :

- Speech
- No mask
- AGC ON in transmit and receive channels
- Normal gain on receive channel
- 1.79MHz input clock (oscillator in stand by)

6 bit Codes

Between two DTMF or ring frequencies, introducing a Mute or speech code implies to wait 1ms to end the sinewave or square period.

DTMF Dialing

To dial in DTMF the following sequence of codes must be sent :

- DTMF Frequency code : 00XXXX
- Dialing Mode code : 010001
- Mute or SPEECH code : 010010 or 010000

The duration of the DTMF signal is fixed by the delay between Dialing mode code and MUTE or SPEECH code.

Pulse Dialing

The pulse dialing function is performed by the

microcontroller through the high voltage stage.

The "MAKE" voltage over the TEA7088A during dialing can be reduced by sending the mask code 0010101. To recover the normal speech voltage at the end of dialing the mask code must be sent again.

If the mask code is not used the voltage over the TEA7088A during dialing is the same as in speech mode.

Ring Indicator (RI)

In ring mode TEA7088A generates a high logic level on Pin RI as soon as the voltage on Pin V_{RING} is higher than $V_{THRI ON}$ (19V Typ.), and the voltage on V_{RMC} is higher than 3.4V.

When the voltage on V_{RMC} becomes higher than 2.6V, RESET signal becomes also high.

Mask Input (MSK)

MSK input must be high by default (Figure 10).

In speech configuration forcing MSK input to low level will have same functionality than the MASK code.

For ring mode when it is necessary to send other frequencies than the 8 basic ones, this input allows to drive the buzzer output.

Figure 9 : DATA/CLOCK Timing

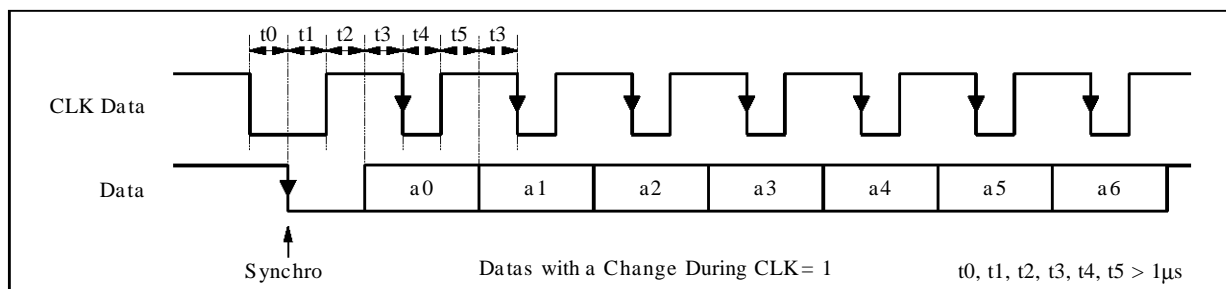
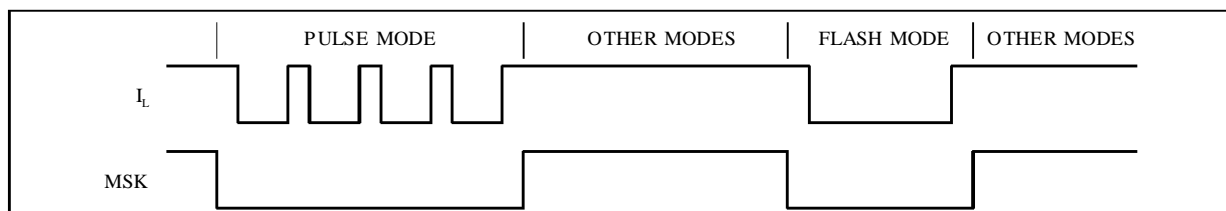

Figure 10 : MASK Timing



MICROCONTROLLER INTERFACE WITH TEA7088A (continued)

Codes						Keyboard	Remarks	
a5	a4	a3	a2	a1	a0			
0	0	0	0	0	0	"2"	1336Hz + 697Hz	In DTMF Dialing
0	0	0	0	0	1	"1"	1209Hz + 697Hz	
0	0	0	0	1	0	"A"	1633Hz + 697Hz	
0	0	0	0	1	1	"3"	1477Hz + 697Hz	
0	0	0	1	0	0	"8"	1336Hz + 852Hz	
0	0	0	1	0	1	"7"	1209Hz + 852Hz	
0	0	0	1	1	0	"C"	1633Hz + 852Hz	
0	0	0	1	1	1	"9"	1477Hz + 852Hz	
0	0	1	0	0	0	"5"	1336Hz + 770Hz	
0	0	1	0	0	1	"4"	1209Hz + 770Hz	
0	0	1	0	1	0	"B"	1633Hz + 770Hz	
0	0	1	0	1	1	"6"	1477Hz + 770Hz	
0	0	1	1	0	0	"0"	1336Hz + 941Hz	
0	0	1	1	0	1	"*"	1209Hz + 941Hz	
0	0	1	1	1	0	"D"	1633Hz + 941Hz	
0	0	1	1	1	1	"#"	1477Hz + 941Hz	
0	0	0	0	0	0		822Hz Ring Signal	In Ring Mode
0	0	0	0	0	1		744Hz Ring Signal	
0	0	0	0	1	0		1005Hz Ring Signal	
0	0	0	0	1	1		909Hz Ring Signal	
0	0	1	1	0	0		1187Hz Ring Signal	
0	0	1	1	0	1		1074Hz Ring Signal	
0	0	1	1	1	0		1451Hz Ring Signal	
0	0	1	1	1	1		1312Hz Ring Signal	
0	1	0	0	0	0		Speech Mode	Speech Mode Dialing Mode or Ring Start Earphone & Microphone Mute Microphone Mute
0	1	0	0	0	1			
0	1	0	0	1	0			
0	1	0	0	1	1			
0	1	0	1	0	1		Mask/No Mask	
0	1	0	1	1	0	"+6dB"	Normal/+6dB on Receive Channel	
0	1	0	1	1	1		Reset Pin Control	
1	1	1	0	1	0		Initialization Code	
0	1	0	1	0	0		AGC / No AGC	
1	0	1	0	0	0		1.79MHz Ext Clock & Oscillator Stand by / 3.58MHz Ceramic (toggle)	
0	1	1	1	0	0		Minimum Ring Level (level 1)	
0	1	1	1	0	1		Intermediate Low Ring Level (level 2)	
0	1	1	1	1	0		Intermediate High Ring Level (level 3)	
0	1	1	1	1	1		Maximum Ring Level (level 4)	

7088A-03.TBL

Figure 11 : Test Circuits - Test 1 (V_L / V_{RMC} / V_{MC} / I_{VMC} / I_{LS})

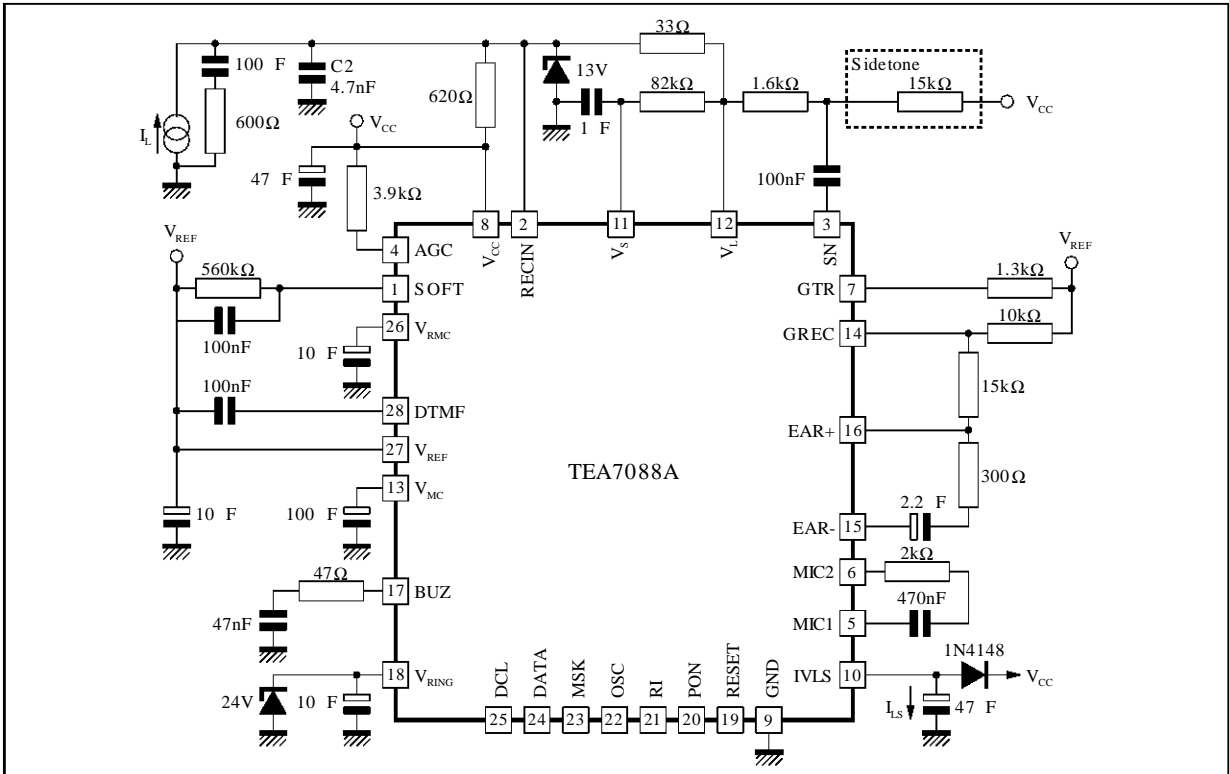

7088A-12.EPS

Figure 12 : Test 2 (R₁)

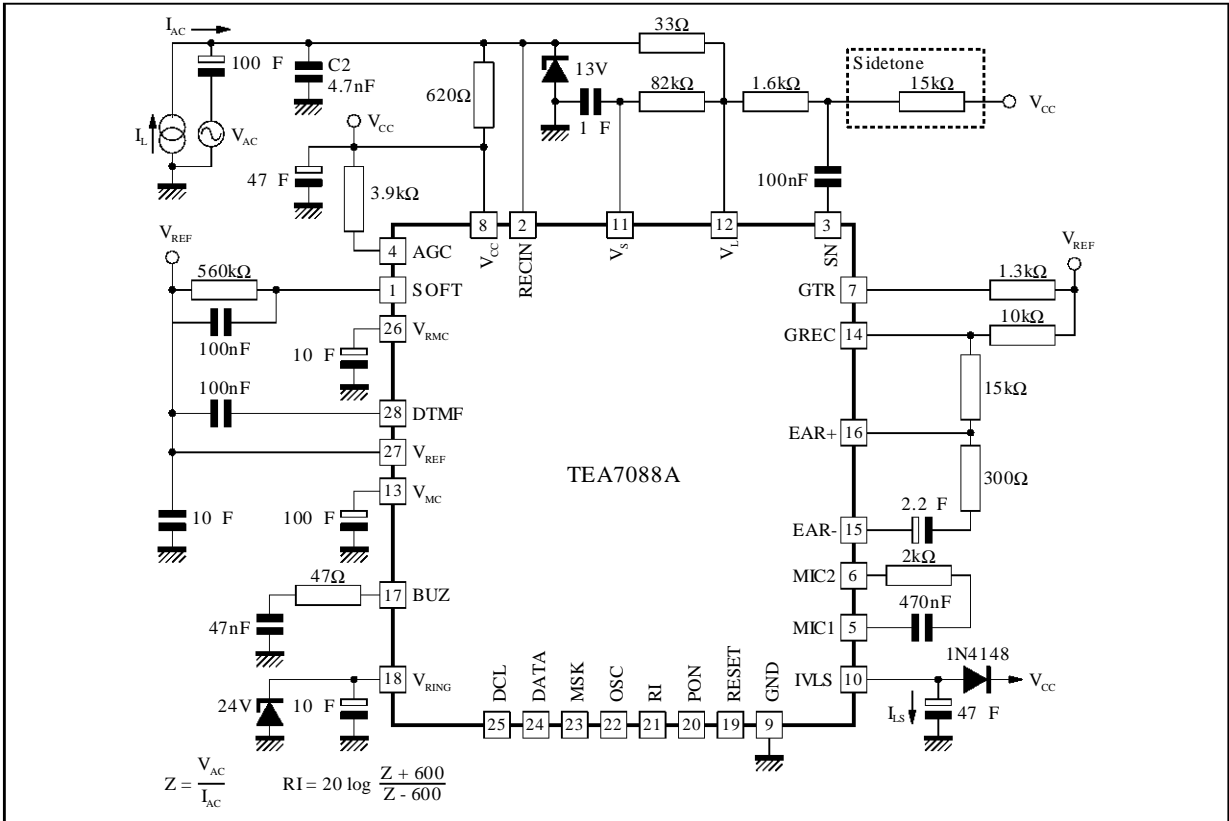

$$Z = \frac{V_{AC}}{I_{AC}}$$

$$R1 = 20 \log \frac{Z + 600}{Z - 600}$$

7088A-13.EPS

Figure 13 : Test 3 (Gtl / Gts / Zmic / Nt / Mmic / Dt / VImax / Eff)

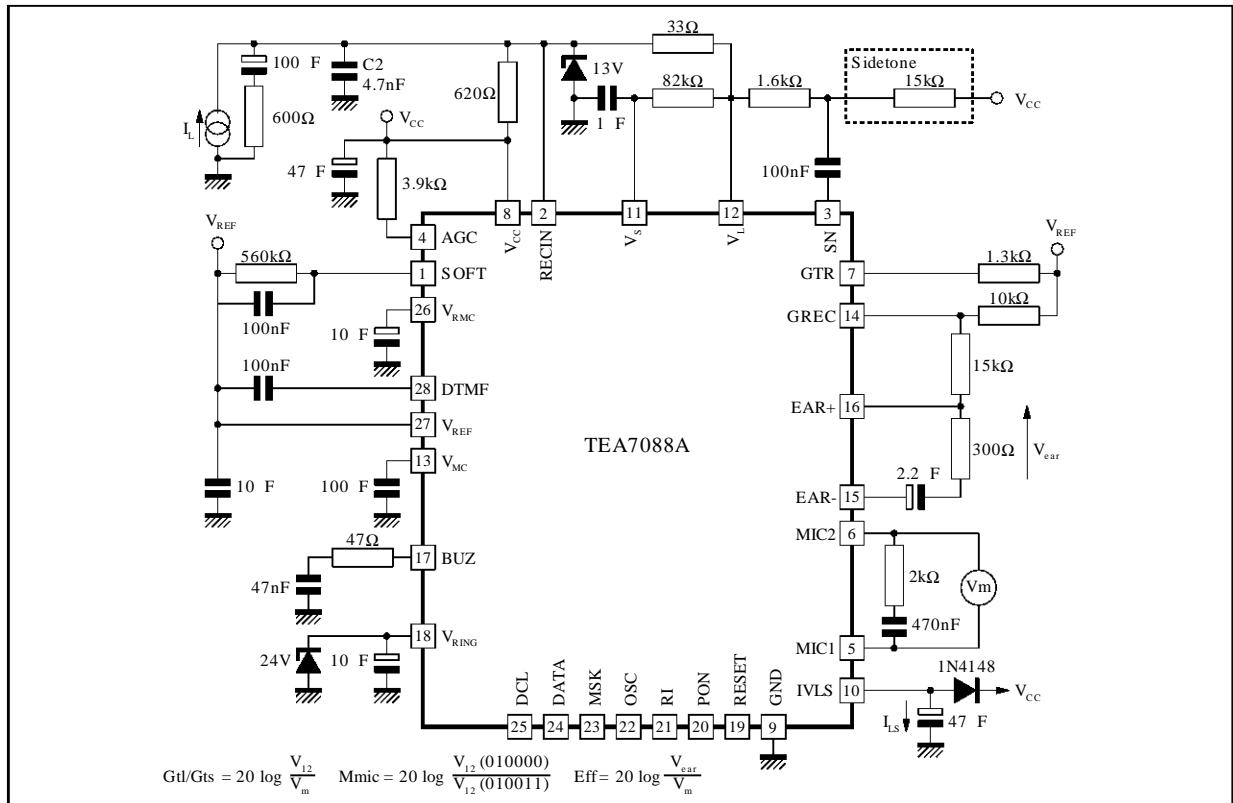

7088A-14.EPS

Figure 14 : Test 4 (Grl / Grs / Dr / Mear / Nr)

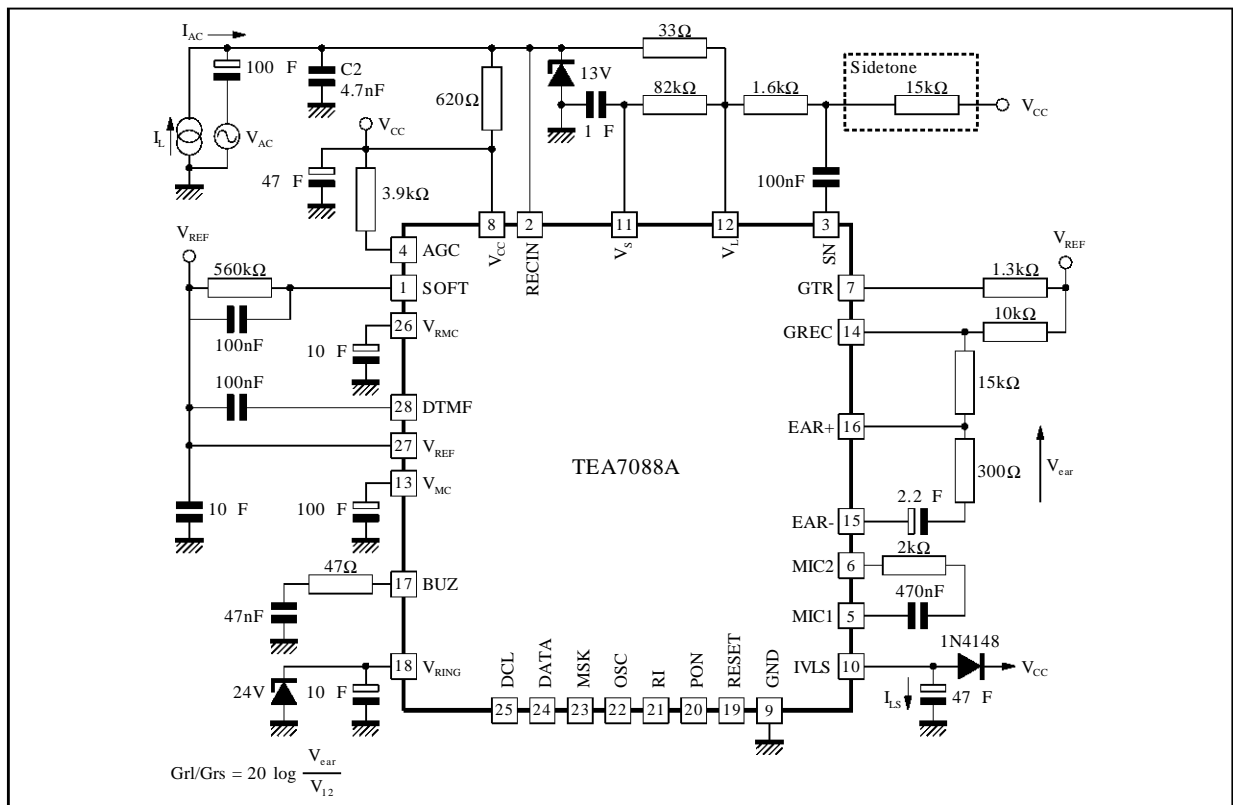

7088A-15.EPS

Figure 15 : Test 5a (V_{thri})

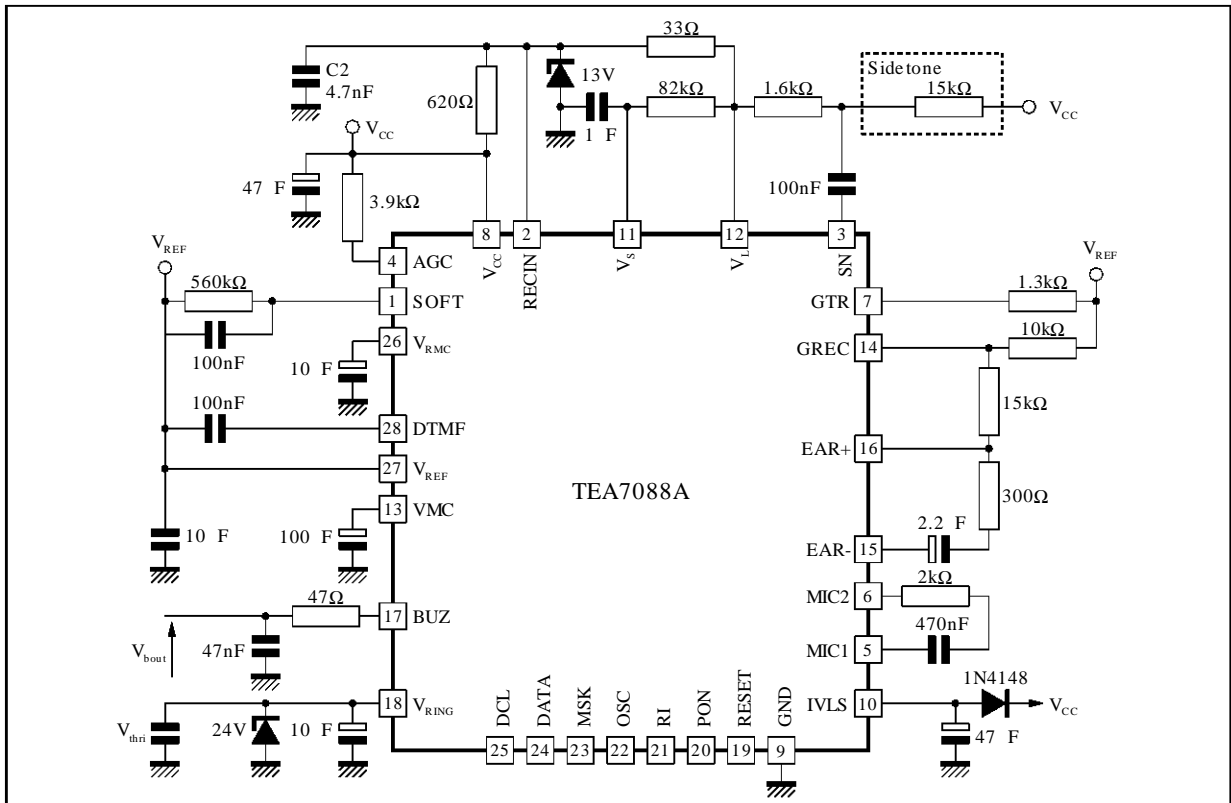

7088A-16.EPS

Figure 16 : Test 5b (V_{bout})

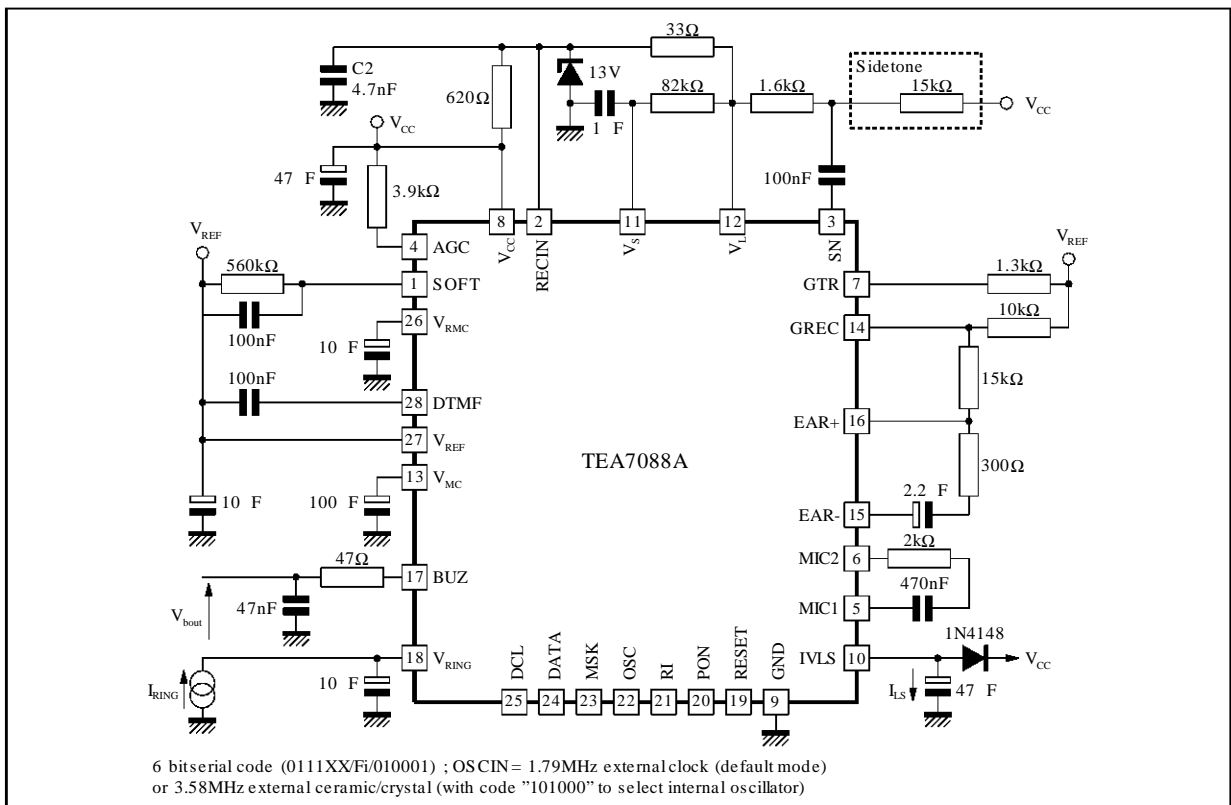

6 bit serial code (0111XXFi/010001) ; OSCIN = 1.79MHz external clock (default mode)
or 3.58MHz external ceramic/crystal (with code "101000" to select internal oscillator)

7088A-17.EPS

Figure 17 : Test 6 (DTMF)

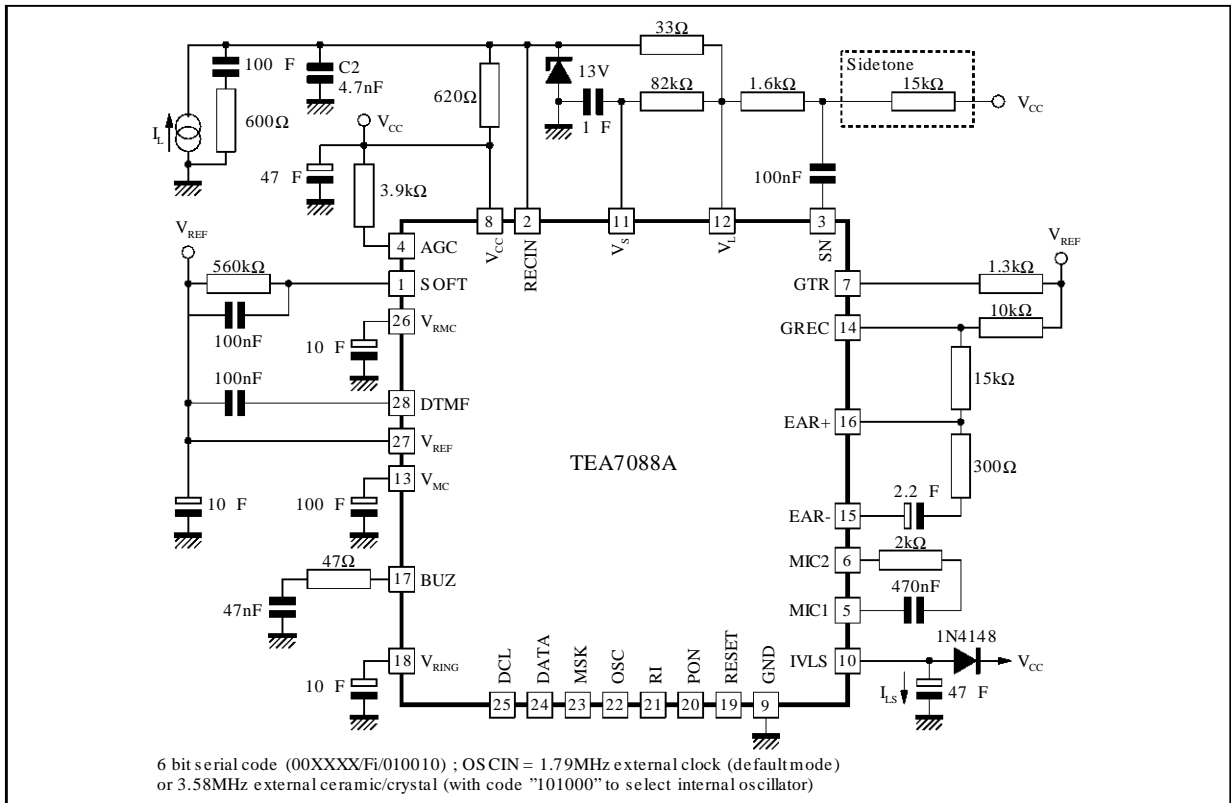

7088A-18.EPS

PACKAGE MECHANICAL DATA
28 PINS - PLASTIC PACKAGE

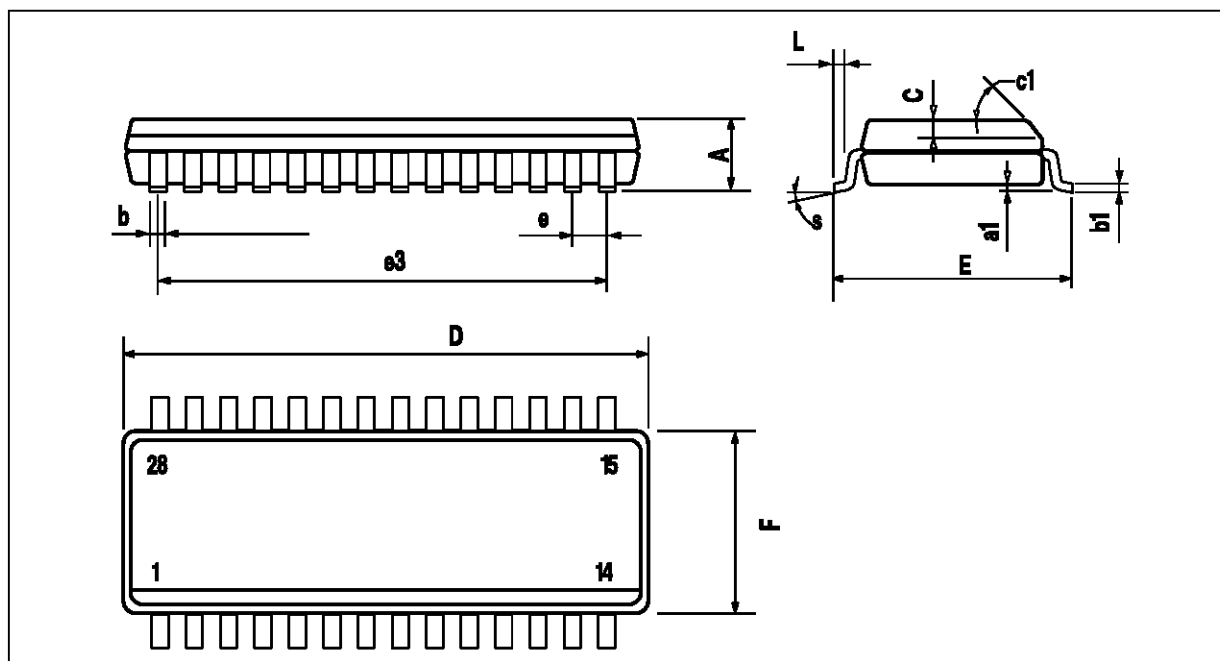

PM-SO28LEFS

Dimensions	Millimeters			Inches		
	Min.	Typ.	Max.	Min.	Typ.	Max.
A			2.65			0.104
a1	0.1		0.3	0.004		0.012
b	0.35		0.49	0.014		0.019
b1	0.23		0.32	0.009		0.013
C		0.5			0.020	
c1	45° (Typ.)					
D	17.7		18.1	0.697		0.713
E	10		10.65	0.394		0.419
e		1.27			0.050	
e3		16.51			0.65	
F	7.4		7.6	0.291		0.299
L	0.4		1.27	0.016		0.050
S	8° (Max.)					

SO28.TBL

Information furnished is believed to be accurate and reliable. However, SGS-THOMSON Microelectronics assumes no responsibility for the consequences of use of such information nor for any infringement of patents or other rights of third parties which may result from its use. No licence is granted by implication or otherwise under any patent or patent rights of SGS-THOMSON Microelectronics. Specifications mentioned in this publication are subject to change without notice. This publication supersedes and replaces all information previously supplied. SGS-THOMSON Microelectronics products are not authorized for use as critical components in life support devices or systems without express written approval of SGS-THOMSON Microelectronics.

© 1996 SGS-THOMSON Microelectronics - All Rights Reserved

Purchase of I²C Components of SGS-THOMSON Microelectronics, conveys a license under the Philips I²C Patent. Rights to use these components in a I²C system, is granted provided that the system conforms to the I²C Standard Specifications as defined by Philips.

SGS-THOMSON Microelectronics GROUP OF COMPANIES

Australia - Brazil - Canada - China - France - Germany - Hong Kong - Italy - Japan - Korea - Malaysia - Malta - Morocco
The Netherlands - Singapore - Spain - Sweden - Switzerland - Taiwan - Thailand - United Kingdom - U.S.A.